

HELICAL FLUTE

ASM Series

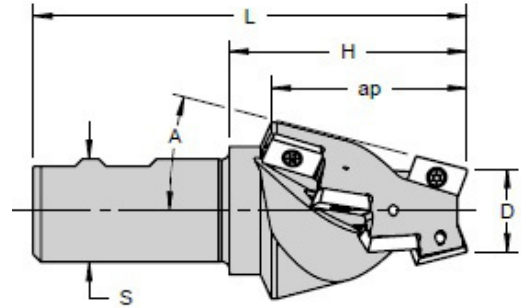

- Designed for roughing angles and milling chamfers and weld preps
- High positive geometry provides free cutting action
- End cutting
- Two indexes per insert
- Special sizes and angles can be quoted
- Cutter bodies made in the USA



Angle A	Part Number	Dimensions (inches)						No. of inserts	No. of Flutes	Insert	Standard Components
		D	OD	S	L	H	ap				
10 MM INSERT											
10°	ASM-10	1.00	1.51	1.00	4.38	2.00	1.44	8	2	APKT 1003	M25T6S21
15°	ASM-15	0.81	1.57	1.00	4.38	2.00	1.41				
20°	ASM-20	0.81	1.81	1.00	4.38	2.00	1.37				
22.5°	ASM-22.5	0.81	1.93	1.00	4.38	2.00	1.35				
25°	ASM-25	0.81	2.04	1.00	4.38	2.00	1.32				
30°	ASM-30	0.81	2.27	1.00	4.25	1.88	1.26				
32.5°	ASM-32.5	0.81	2.38	1.00	4.25	1.88	1.23				
41°	ASM-41	0.81	2.73	1.00	4.13	1.75	1.10				
45°	ASM-45	0.81	2.87	1.00	4.13	1.75	1.03				
60°	ASM-60	0.81	3.34	1.00	3.88	1.50	0.73				
16 MM INSERT											
10°	ASML-110	1.38	2.18	1.25	5.25	2.88	2.27	8	2	APKT 1604	M40T6S31
15°	ASML-115	1.00	2.20	1.25	5.25	2.88	2.23				
20°	ASML-120	1.00	2.58	1.25	5.19	2.82	2.17				
22.5°	ASML-122.5	1.00	2.77	1.25	5.19	2.82	2.13				
25°	ASML-125	1.00	2.95	1.25	5.13	2.75	2.09				
30°	ASML-130	1.00	3.31	1.25	5.13	2.75	2.00				
32.5°	ASML-132.5	1.00	3.48	1.25	5.13	2.75	1.95				
37.5°	ASML-137.5	1.00	3.79	1.25	5.00	2.63	1.81				
41°	ASML-141	1.00	4.03	1.25	4.94	2.57	1.74				
45°	ASML-145	1.00	4.27	1.25	4.88	2.50	1.63				
60°	ASML-160	1.00	5.00	1.25	4.38	2.00	1.15				

Size	Part Number	IC	Thickness	Corner Radius	Coatings				Image
					None	TiCN	TiN	TiAlN	
10 mm	APKT 1003 PDTR	0.264	0.137	0.019	○	○	●	●	
16 mm	APKT 1604 PDTR	0.375	0.187	0.031	○	○	○	●	